

General Description

The MP1022A is a Power IC that offers a complete solution for driving a single Cold Cathode Fluorescent Lamp (CCFL). This Power IC converts unregulated DC voltage to a nearly pure sine wave required to ignite and operate the CCFL.

Based on proprietary power topology and control techniques (patents pending), it greatly increases the power conversion efficiency. The MP1022A supports both analog and burst mode dimming simplifying the module implementation. The MP1022A offers these distinct performance advantages:

1. More light for less power
2. Small board implementation
3. Low RF emission
4. Low external components cost

Ordering Information

Part Number *	Package	Temperature
MP1022EMA	TSSOP20	-20°C to +85°C
EV0002	Evaluation Board	

* For Tape & Reel use suffix - Z (i.e. MP1022EMA-Z)

Features

- Input Voltage V_{IN} = 4.5V to 5.5V
- Increase transformer reliability
- Open lamp timer and regulation
- Current and Voltage feedback control
- Logic Level burst mode control
- 1.0V to 12V power input
- Supports Open/Short Lamp protection
- Soft Start
- Outputs are short circuit protected
- Allows Burst-Mode Operation
- Improved line transient response
- Tightened lamp current accuracy
- **2 Watt Evaluation Board Available**

Applications

- LCD backlight inverter for handheld display applications similar to: Camcorders, Digital cameras, HPC, GPS

Figure 1: Typical Application Circuit

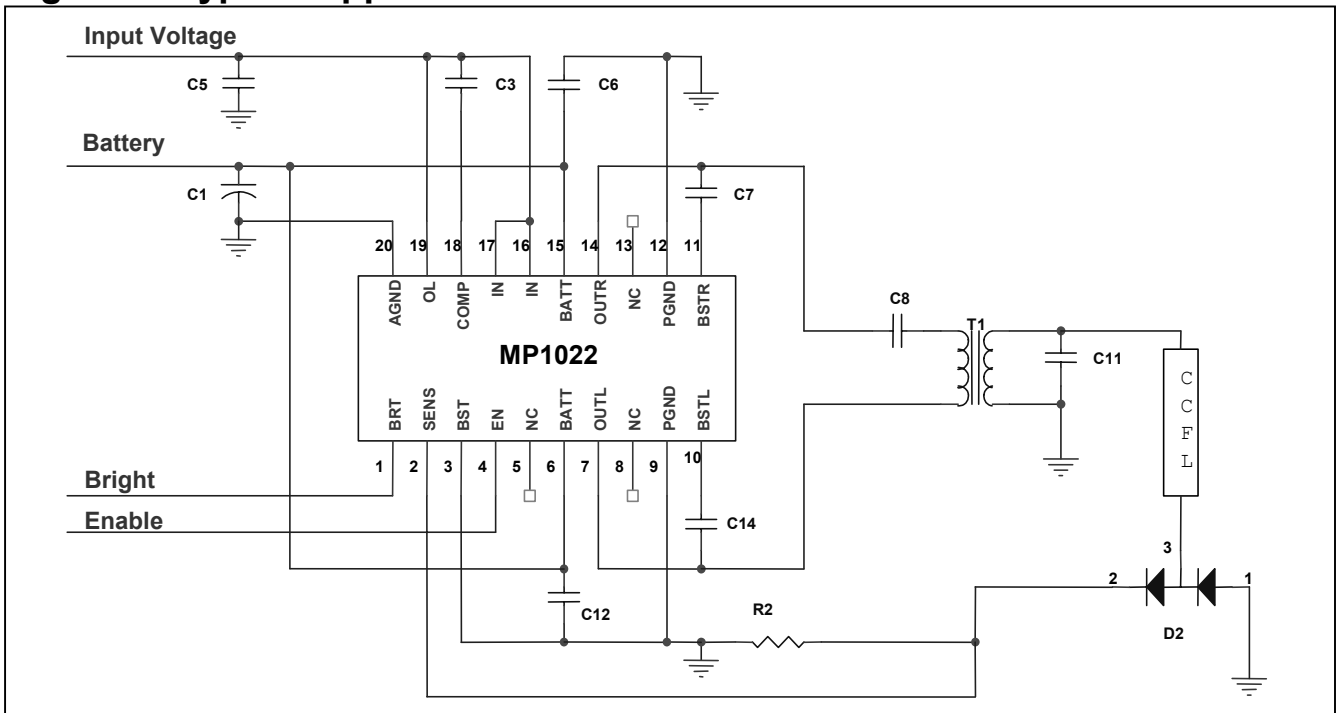

Absolute Maximum Ratings

Battery Voltage V_{BATT}	14 V
Input Voltage V_{IN}	5.5V
Logic Inputs	0.3V to Vdd+0.3V
Power Dissipation	1.0W
Junction Temperature	150° C
Operating Frequency	150KHz
Lead Temperature (Solder)	260°C
Storage Temperature	-55°C to 150°C

Recommended Operating Conditions

Battery Voltage V_{BATT}	1.0V to 12V
Input Voltage V_{IN}	4.5V to 5.5V
Enable Voltage V_{EN}	0 to 5.0V
Brightness Voltage	0 to 2.0V
Operating Frequency	60KHz
Operating Temperature	-20° C to + 85° C

Thermal Characteristics

Thermal resistance	140° C/W
--------------------	----------

Electrical Characteristics (Unless otherwise specified $V_{BATT} = 5 V$, $V_{IN} = 5 V$, $T_A = 25^\circ C$)

Parameters	Symbol	Condition	Min	Typ	Max	Units
Voltage Supply						
Vcc Operating range	V_{BATT}	(Note 2)	1.0		12	V
Vdd Operating range	V_{IN}		4.5	5.0	5.5	V
Vdd Off Current	$I_{DD(OFF)}$	$V_{EN} = 0V$		120	300	μA
Vcc Off Current	$I_{CC(OFF)}$	$V_{BATT} = 10V, V_{EN} = 0V$			10	μA
Vdd Current (operating)	$I_{DD(ON)}$			1.8	2.5	mA
Shutdown Logic						
Open Lamp Detect	V_{OL}		1.0	1.2	1.4	V
Enable Voltage Low	V_{IL}				0.6	V
Enable Voltage High	V_{IH}		2.0			V
Burst Logic						
Burst Pin Threshold	V_{TH}			1.5		V
Burst Pin V_{TH} Hysteresis	dV_{TH}			0.1		V
Input Bias Current	I_{IN}			1		μA
Output Drivers						
On Resistance	R_{ON}	(Note 1)	0.10	0.12	0.15	Ω
Short Circuit Current	I_{SC}			4		A
Operating Frequency			20	60	90	KHz
$T_{ON(MIN)}$		$V_{BATT} = 5V, V_{COMP} = 0V$	0.80	1.00	1.20	μS
$T_{ON(MIN)}$		$V_{BATT} = 10V, V_{COMP} = 0V$	0.45	0.60	0.80	μS
Brightness Control						
Sense Full Brightness	V_{SENS}	$V_{BRT} = 2.0V$	357	375	393	mV
Sense Full Dim	V_{SENS}	$V_{BRT} = 0V$	82	92	101	mV
Lamp Current Regulation		$1.0V < V_{BATT} < 10V$		2	5	%

Note 1: This parameter is guaranteed by design.

Note 2: See leakage inductance guidelines for minimum operating voltage (Table 1).

Table 1: Pin Description

Pin Name	Pin Name	Pin Function
1	BRT	Dimming Control: 0 volts is full Dim and 2V is full brightness
2	SENS	Lamp current feedback sense input, 0.375V DC is full current
3	BST	For burst mode, the pin is switched between 0V and 5V When not using burst mode, then pin must be tied to ground.
4	EN	The enable will turn the chip on/off. Do not float this pin.
5	NC	No Connect
6	BATT	Battery voltage Input
7	OUTL	Output to Load (tank circuit)
8	NC	No Connect
9	PGND	Power Ground
10	BSTL	Regulated output voltage for boost cap on phase L
11	BSTR	Regulated output voltage for boost cap on phase R
12	PGND	Power Ground
13	NC	No Connect
14	OUTR	Output to Load (tank circuit)
15	BATT	Battery voltage Input
16	IN	Supply Voltage
17	IN	Supply Voltage
18	COMP	Loop compensation cap
19	OL	Latching shutdown for open lamp or low battery
20	AGND	Small signal ground

Figure 2: Functional Block Diagram

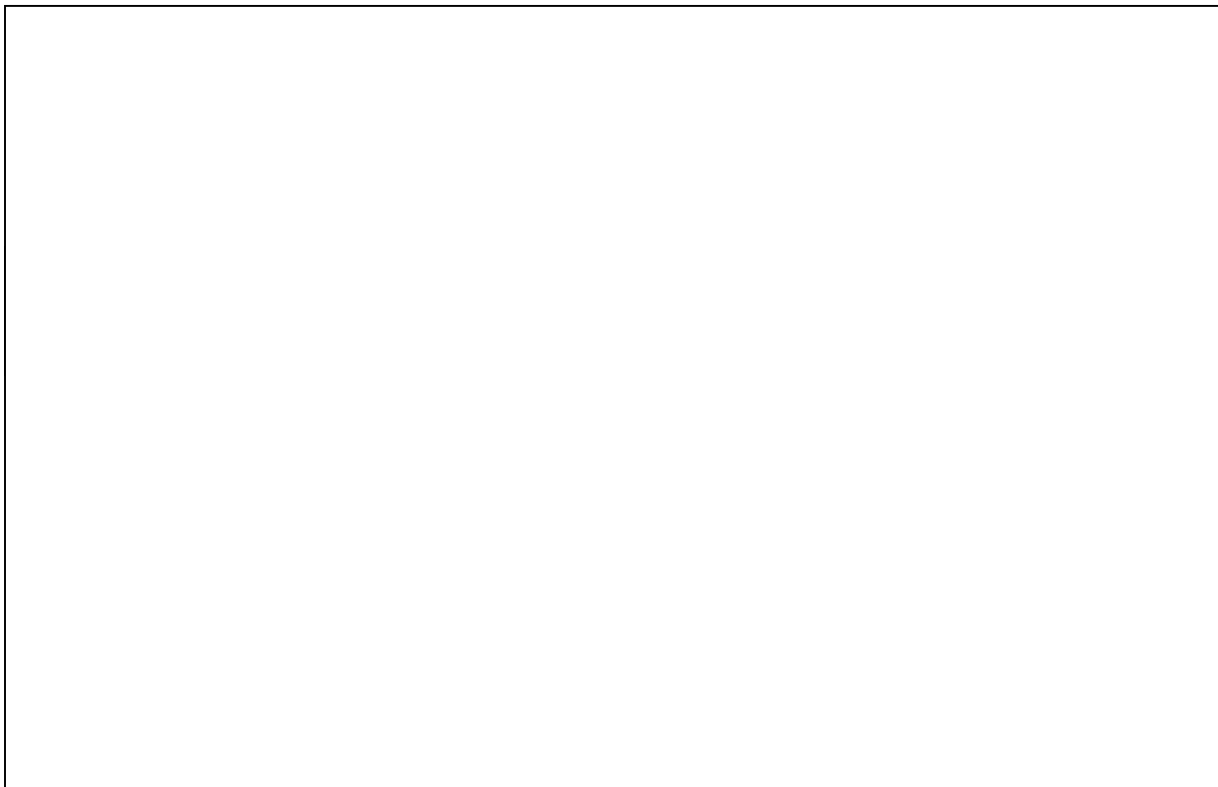

Packaging Information

20 Pin TSSOP

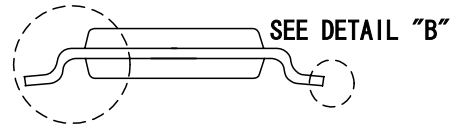
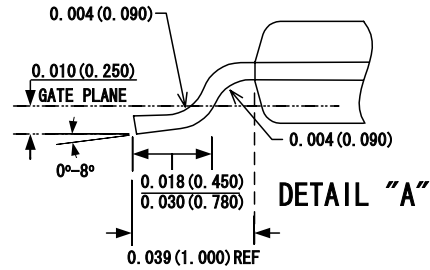
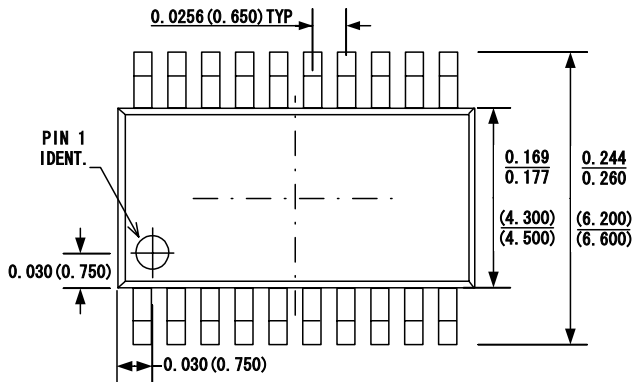

SEE DETAIL "A"

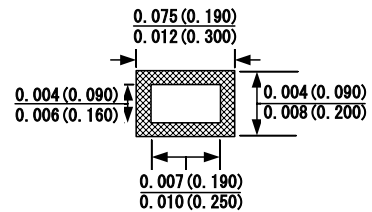
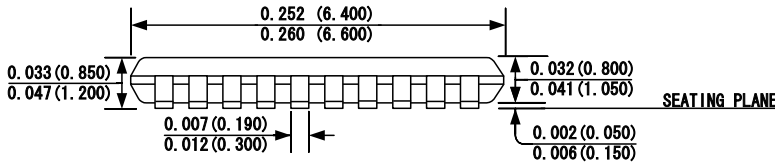

DETAIL "B"

NOTE:

1) Control dimension is in inches. Dimension in blanket is millimeters.

NOTICE: MPS believes the information in this document to be accurate and reliable. However, it is subject to change without notice. Please contact the factory for current specifications. No responsibility is assumed by MPS for its use or fit to any application, nor for infringement of patent or other rights of third parties.