

General Description

The MP1519 is a fully automatic driver for powering up to four (4) white LEDs, with up to 4V forward voltage, off of a single Li-Ion or three NiMH cells. The driver performs all the sensing and control to run the LEDs at an optimum charge pump ratio for efficiency without an expensive inductor. The driver will sense and ignore missing LEDs and will allow PWM operation to support brightness control.

The tiny 3mm x 3mm QFN16 package and small external capacitors allow for the most compact white LED solution available.

Ordering Information

Part Number*	Package	Temperature
MP1519DQ	QFN16 (3x3)	-40°C to +85°C
EV0042	Evaluation Board	

* For Tape & Reel use suffix - Z (e.g. MP1519DQ-Z)

Features

- 2% LED Current Matching
- High Efficiency (>93%)
- Current Source Outputs
 - No Ballast Resistors Required
- 1x, 1.5x and 2x Automatic Modes
- Constant Frequency Operation
- Automatic LED Detection
- High and Low Frequency PWM Capability
- 2.5V to 5.5V Operation
- Less than 1µA Leakage during Shutdown
- Detects Changes in Battery Level
- No External Schottky Diode Required
- Soft Start and Soft Switch Operation
- **Evaluation Board Available**

Applications

- Cell Phones
- PDA or Hand Held Computers
- White LED Application at 3.6V Supply

Typical Application Circuit

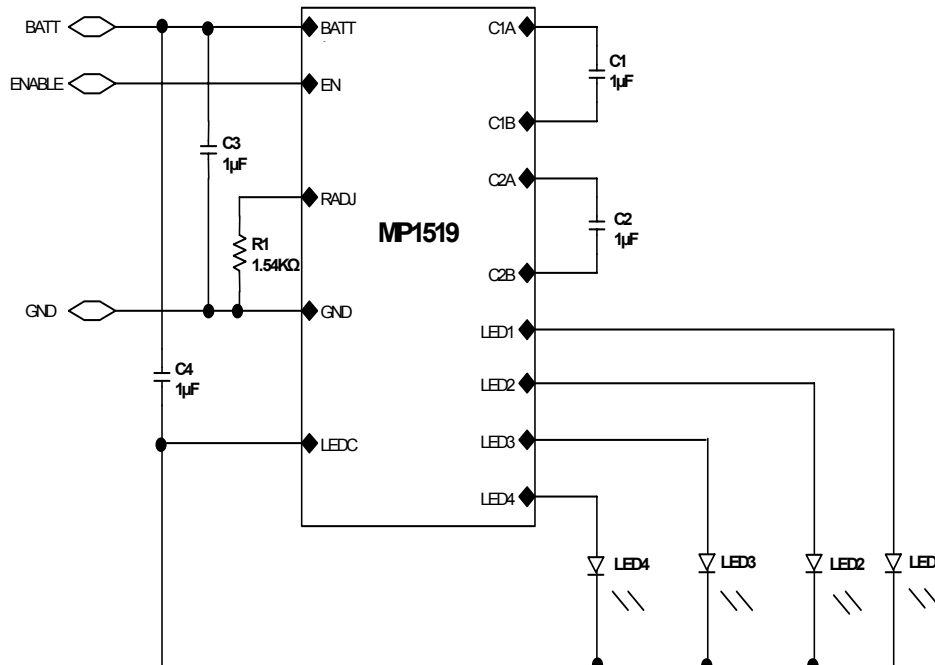

PRELIMINARY

Absolute Maximum Ratings (Note 1)

V _{BATT} to GND	7V
Power Dissipation (QFN)	1.0 W
Logic Inputs to GND	-0.3V to 6.5V
Storage Temperature	-55 °C to 150 °C

Recommended Operating Conditions (Note 2)

Input Voltage V _{BATT}	2.5V to 5.5V
Operating Temperature	-40 °C to + 85 °C

Thermal Characteristics

Thermal resistance (QFN)	60°C/W
Junction Temperature	150 °C

Electrical Specifications (Unless otherwise specified: V_{BATT} = 5V, T_A=25 °C)

Parameters	Symbol	Condition	Min	Typ	Max	Units
Input Supply Voltage	V _{BATT}		2.5		5.5	V
V _{BATT} at 1x to 1.5x Mode Switch	V _{BATT 1x-1.5X}	I _{LED} =20mA, V _{BATT} Decreasing, V _{LED} =3.35V @ 20mA		TBD		V
V _{BATT} at 1.5x to 2x Mode Switch	V _{BATT 1.5x-2X}	I _{LED} =20mA, V _{BATT} Decreasing, V _{LED} =3.35V @ 20mA		TBD		V
V _{BATT} at 1.5x to 1x Mode Switch	V _{BATT 1.5x-1X}	V _{BATT} Increasing, V _{LED} =3.35V @ 20mA		TBD		V
V _{BATT} at 2x to 1.5x Mode Switch	V _{BATT 2x-1.5X}	V _{BATT} Increasing, V _{LED} =3.35V @ 20mA		TBD		V
Supply Current	I _{BATT}	4 LEDs at 20mA; 2x Mode, V _{BATT} =2.5V		164		mA
Supply Current Shutdown	I _{BATT SHDN}	V _{EN} = 0V		0.1	1	µA
Current Matching	I _{BATT MATCH}	I _{LED} = 20mA (Note 4)		2	TBD	%
Enable Voltage, High	V _{EN (HIGH)}			2.1		V
Enable Voltage, Low	V _{EN (LOW)}			1.0		V
Enable Pin Leakage	I _{EN}	V _{EN} =5V		0.1	1	UA
Charge Pump Frequency	F _{CP}	V _{BATT} = 3.3V	1.0	1.3	1.6	MHz
Time to Standby Mode	T _{OFF}	Enable Switched Low (Note 3)		30		µs
Enable Pin PWM Frequency Limit	F _{HPWM}			50		KHz
LED Current	I _{LED}	R _{SET} =1.5KΩ		20		mA

Note 1. Exceeding these ratings may damage the device.

Note 2. The device is not guaranteed to function outside its operating rating.

Note 3. Standby mode switches to shutdown when the output voltage on LEDC drifts back to GND.

Note 4. Matching is defined as the difference of the maximum to minimum current divided by the sum of the currents.

Pin Description

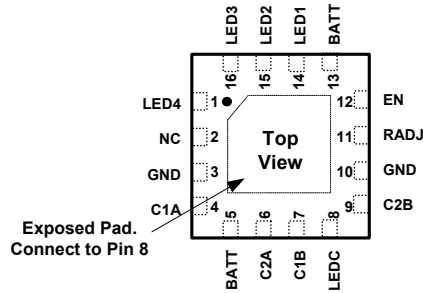

Table 1: Pin Designators

Pin #	Name	Description
1	LED4	#4 LED Driver. Connect the #4 LED between LED4 and LEDC, with the anode at LED4, and the cathode at LEDC. If the #4 LED is not used, leave LED4 unconnected.
2	NC	No Connect
3, 10	GND	Ground
4	C1A	Charge Pump Capacitor #1 Positive Node. Connect the positive side of the #1 charge pump capacitor to C1A. Typical applications require C1 to be 1 μ F.
5, 13	BATT	Battery Power Input. Connect the 2.5V to 5.5V input source between BATT and GND. Bypass BATT to GND with a 1 μ F or greater capacitor.
6	C2A	Charge Pump Capacitor #2 Positive Node. Connect the positive side of the #2 charge pump capacitor to C2A. Typical applications require C2 to be 1 μ F.
7	C1B	Charge Pump Capacitor #1 Negative Node. Connect the negative side of the #1 charge pump capacitor to C1B.
8	LEDC	LED Common for the Cathodes. Connect the cathodes of the LEDs to LEDC and to a 1 μ F bypass capacitor. Do not connect to any other ground, supply or pin. Note: Exposed pad on backside is connected to this pin. Do not Ground!!
9	C2B	Charge Pump Capacitor #2 Negative Node. Connect the negative side of the #2 charge pump capacitor to C2B.
11	RADJ	LED Current Adjust Input. Connect a resistor between RADJ and GND to set the LED current. All of the LEDs regulate at the same current. See <i>Setting the LED Current</i> .
12	EN	Enable Input. Drive EN high to turn on the MP1519, drive EN low to shut down the MP1519. To use burst-mode brightness control, drive EN with a PWM signal. See <i>Burst Mode Dimming</i> .
14	LED1	#1 LED Driver. Connect the #1 LED between LED1 and LEDC, with the anode at LED1, and the cathode at LEDC. If the #1 LED is not used, leave LED1 unconnected.
15	LED2	#2 LED Driver. Connect the #2 LED between LED2 and LEDC, with the anode at LED2, and the cathode at LEDC. If the #2 LED is not used, leave LED2 unconnected.
16	LED3	#3 LED Driver. Connect the #3 LED between LED3 and LEDC, with the anode at LED3, and the cathode at LEDC. If the #3 LED is not used, leave LED3 unconnected.

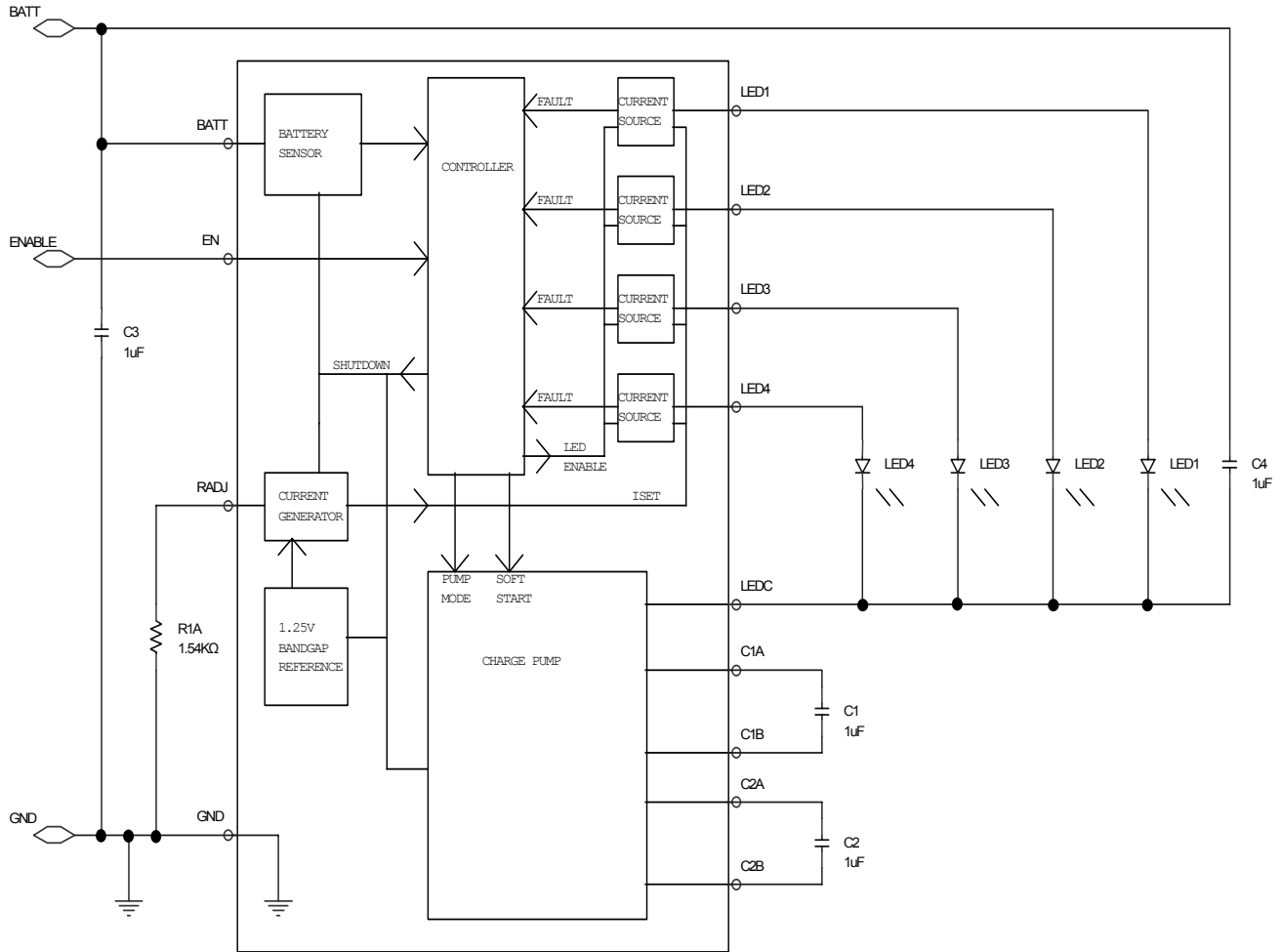

Figure 1: Block Diagram

Functional Description

The MP1519 is a charge pump that drives up to 4 LEDs from a 2.5V to 5.5V input voltage. It automatically switches between 1x, 1.5x and 2x charge pump modes to optimize efficiency while maintaining LED current regulation.

Four drivers independently regulate the current through the LEDs, therefore matching LEDs are not required. The MP1519 employs soft switching and soft start to prevent overloading the battery source at turn-on and charge pump mode switching.

While operating, the MP1519 continually monitors the LED current and battery voltage and automatically switches between charge pump modes to retain LED current regulation through all LEDs as the battery voltage fluctuates.

Application Information

Start Up

When power is applied to the V_{BATT} driving EN high will enable the MP1519. The MP1519 begins by checking for open LEDs and determining the optimum charge pump mode. The lowest charge pump mode that allows the programmed LED current in all LEDs is set. This will occur during initial turn-on or during analog mode and burst mode dimming.

Shut Down

Driving EN low for more than $30\mu s$ will disable the MP1519. For safety the MP1519 runs a small supervisory circuit in standby to protect the charge pump output LEDC. The circuit shuts down when the charge pump output returns to zero volts (this can take a few seconds). The MP1519 is in true shut down mode when LEDC is zero and the $30\mu s$ time interval has passed. The supply current should be less than $1\mu A$.

Setting the LED Current

The LED regulation current is set through the resistor R1 (Typical Application page 1). The voltage across R1 is fixed at 1.25V, and the current through that resistor sets the current through the LEDs.

Figure 2 shows LED Current (I_{LED}) vs. R1 with $V_{BATT} = 3.6V$.

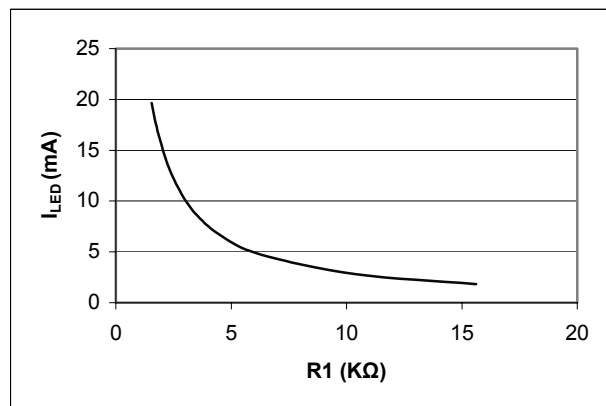

Figure 2: I_{LED} vs. R1

Choose R1 for the desired LED current according to the equation:

$$R1 = 31.25 / I_{LED}$$

Where R1 is in $K\Omega$, and I_{LED} is in mA. Suitable values for R1 are greater than $1.2K\Omega$.

Soft Start

During start up and mode switching, an internal soft start prevents excessive input current, preventing excessive loading of the battery or input power source.

Burst Mode Dimming

To dim the part using burst mode, drive EN with a PWM signal. Each time EN is driven high, the MP1519 goes through the initial start up routine and checks for open LEDs, and the charge pump step-up mode is reset.

When EN goes low, the LED current immediately goes to zero. After EN is held low for $30\mu s$ or longer, and LEDC falls below GND, the MP1519 operating current drops below $1\mu A$ to improve battery life. Maintain the frequency of the PWM signal between 50Hz and 50KHz. Above 50KHz the accuracy of the PWM signal will be degraded due to the start up time, and below 50Hz, the LED flicker will be evident to the eye.

Analog Mode Dimming

Analog dimming can be accomplished with the circuit in Figure 7. The circuit provides 1 to 15mA dimming with $V_{DC} = 0$ to 3V. The minimum LED current the MP1519 can regulate is approximately 1mA. Figure 8 shows I_{LED} vs. V_{DC} characteristics of Figure 7 with $V_{BATT} = 3.6V$.

LEDC

Do not drive or force LEDC as it may be shorted to ground or may be pumped down by the controller in the MP1519 at any time. Excessive capacitance on the LEDC node can cause the internal controller to time out before the charge pump can be ready. Missing the time outs will cause excessive pumping and a loss of efficiency. See Typical Application on page 1 for recommended component selection. The MP1519 requires C1 and C2 be the same value and type.

Performance Characteristics (page 1 Typical Application Circuit Applies)

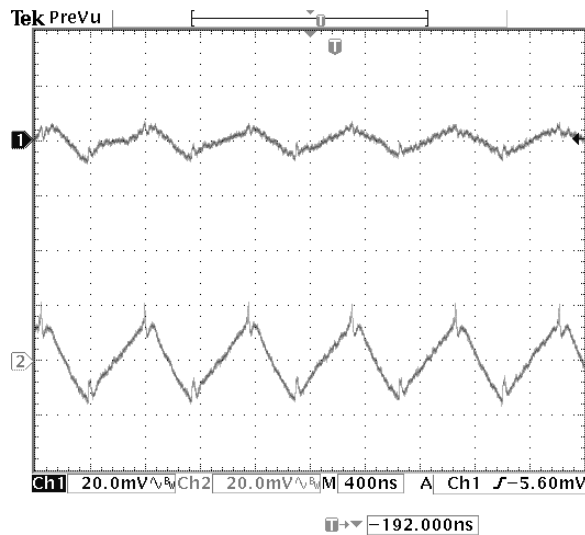

Figure 3: Typical Voltage Ripple Waveforms in 1.5x Mode

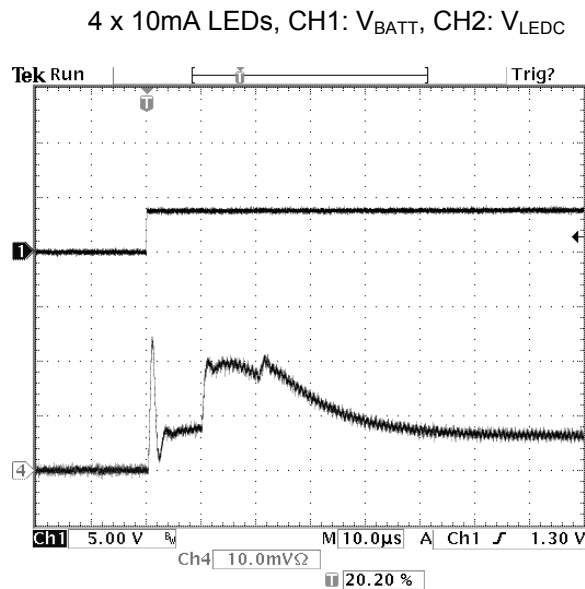

Figure 4: Start Up Waveforms in 1.5x Mode
4 x 10mA LEDs,
CH1: V_{EN} , CH4: I_{BATT} (100mA/div)

Performance Characteristics (page 1 Typical Application Circuit Applies)

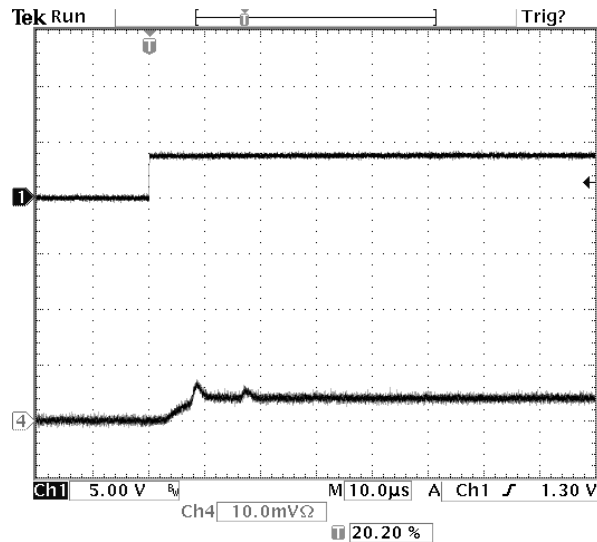

Figure 5: Start Up Waveforms in 1x Mode
 4 x 10mA LEDs
 CH1: V_{EN} , CH2: I_{BATT} (100mA/div)

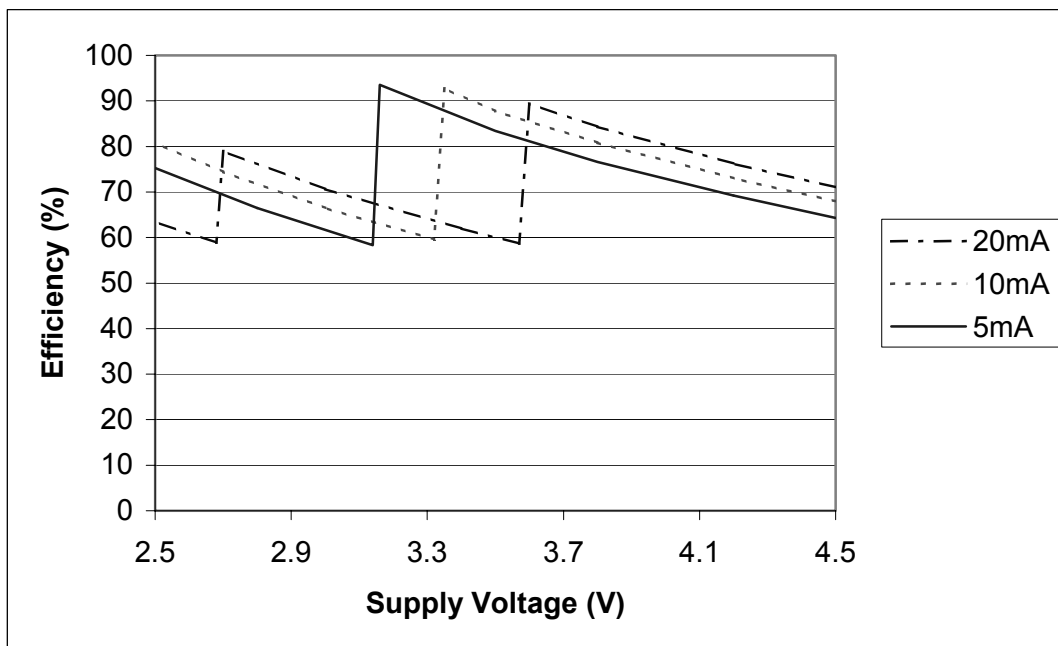

Figure 6: Efficiency vs. Supply Voltage

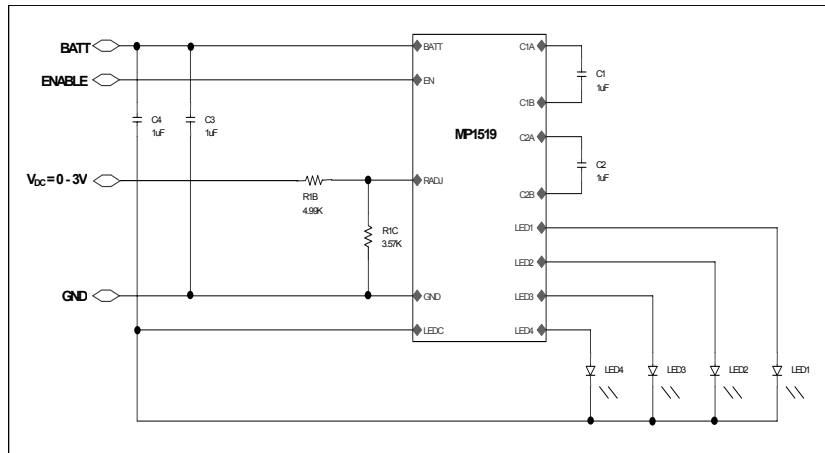

Figure 7: Analog Dimming Circuit

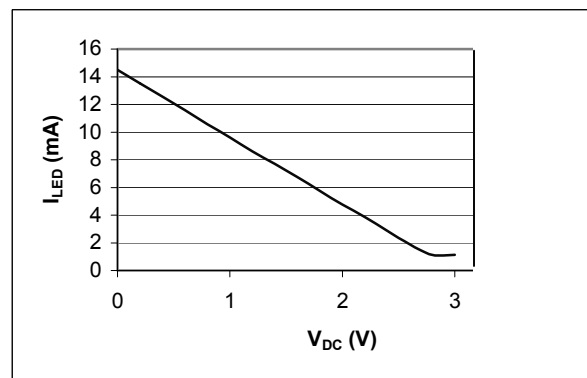

Figure 8: I_{LED} vs. V_{DC} for Analog Dimming

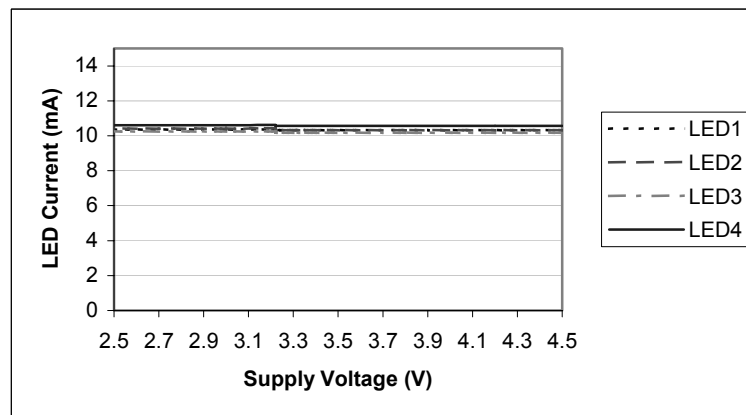
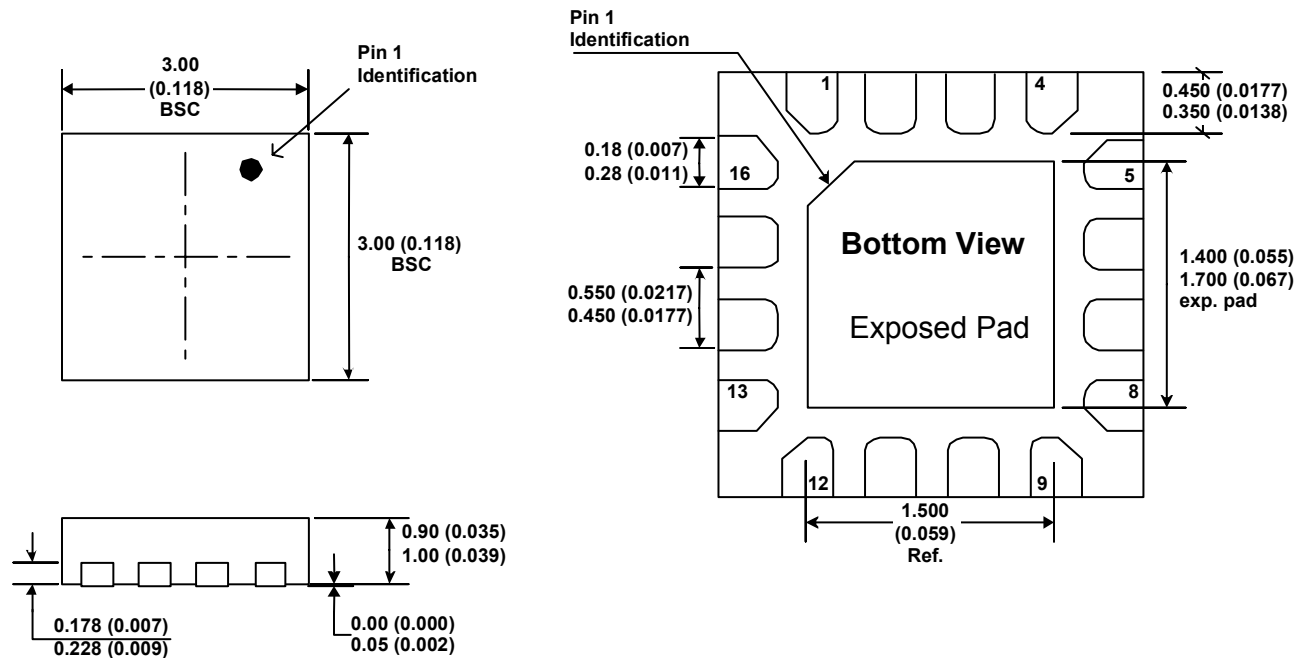

Figure 9: LED Current Matching vs. Supply Voltage

Packaging

QFN16



NOTE:

1) Control dimension is in millimeters. Dimension in bracket is inch.

NOTICE: MPS believes the information in this document to be accurate and reliable. However, it is subject to change without notice. Please contact the factory for current specifications. No responsibility is assumed by MPS for its use or fit to any application, nor for infringement of patent or other rights of third parties